

Extension of the Use of the “Bond-Graphs” for the Knowledges Processing

Doucet Jean Alphonse
Haute Ecole Rennequin Sualem ,
Département Ingénieurs Industriels
Province de Liège
Quai Gloesener 6 B- 4020 Liège
Fax: 04/ 344 64 11 Email: cerisil @ cci.be.

Abstract

By observing the operational power of the well known structures of the “Bond- Graphs” it is rather obvious that they can bring a valuable help for the topological configurations of the operational storage of informations, that are equivalent to modulations.

At first, we survey the main specificities of the “Bond- Graphs” used in the energetics for the description of the energy and power flows. From this starting point we deduce the basic influence of the dual structure of the associated variables for describing any kind of flows.

Consequently following the duality path, we reach the tensor spaces where the products of covariant and contravariant factors produce invariante ones, what is the essential property of these tensor configurations. Afterward, an operational analysis of the modulations can also show their intrinsic dual constitution.

We let also discover the formal analogy between modulation and any classification of information. This important constatation underlines the mutual influence between the kind of the used key referentials (covariant frame) and the deep structure of the memorized knowledges (contravariant quantity).

Keywords: “Bond-Graphs”, Tensor characteristics, Structural duality,
Vector partition of informations, Modulation.

1 Introduction

1.1 Structure and Origin of “Bond-Graphs”

They are symbolic operators elaborated by Karnopp D., Margolis D., Rosenberg.(1990) to display graphically the Power and Energy Flows with a view to explain the dynamic behaviour of every system by means of an associated Flows Topography.

These classical “Bond-Graphs” are drawn on a compacted picture with a single rod (Fig.1). Of this way, their memory allocation is drastically reduced but on the other side their didactical efficacy is also strongly limited and it gives no possibility for pointing out the behaviour between the storage devices and the other ones.

Therefore we thought to develop a more expanded synoptical tool with a couple of rods as already exposed in a previous communication (Doucet, 1998) (Fig.2). It is possible to specify these last stuctures by the denomination of “both rods Bond-Graphs” or by the usual condensed expression: (B.G.)² what will be selected here.

By means of our (B.G.)² structures, we can show every operational performance of the “Bond-graphs” and highlight the duality inside the couple of both conjugated factors of any flow. For specifying the storage elements, we use (B.G.)² with a single lip, what is is to remind of the remaining flows related to the previous flows fluctuations, in these accumulators (Fig.3). Therefore the Storage Bond, with a single lip, is used like the fixed

topographical icon for Derivative or Integral Operator between both rods factors.

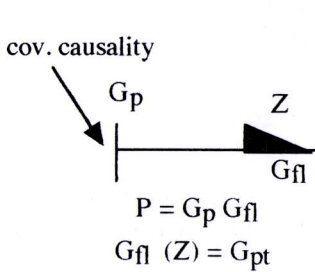

Fig. 1: Presentation of the classical "Bond Graph" of Karnopp with single rod

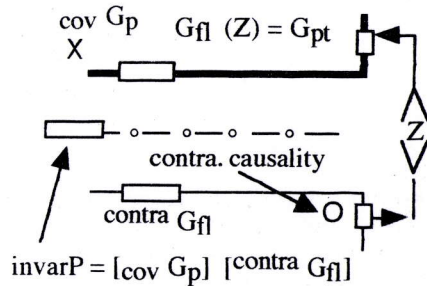
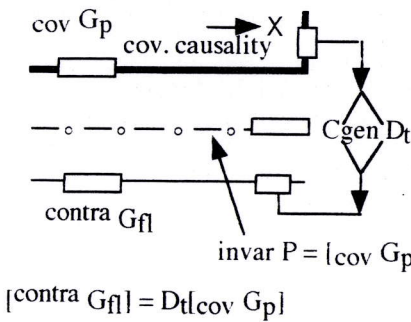
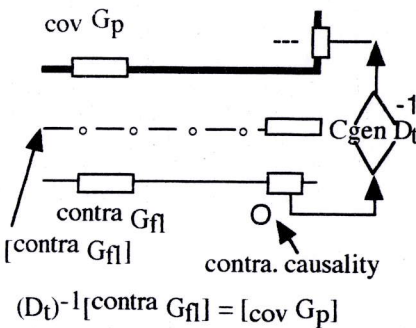

Fig. 2: Presentation of our technological Power (B.G.) with both rods



3a Derivative Operator



3b Integral Operator

Fig. 3: Presentation of the (B.G.) of a Storage Element

1.2 Operational Properties of each Bond

In the table (1), we draw up an inventory of the lot of informations carried by each bond. Consequently the "Bond-Graphs" methodology allows to describe the behaviour of various systems with a whole deep insight. Each bond is a condensed directory of the set of modifications exerted by the systems on the flows.

Relations carried by a Bond:

$$\text{Product or Power relation (fundamental) : } [\text{covGp}] [\text{contraGfl}] = [\text{invarP}] \quad (1)$$

$$\text{Performance Relation: } [\text{contraGfl}] [\text{Zgen}] = [\text{covGp}] \quad (2)$$

$$\text{Inverted Performance Relation: } [\text{covGp}] [\text{Ygen}] = [\text{contraGfl}] \quad (3)$$

$$\text{with } [\text{Zgen}] = \text{covG} / \text{contraG} : \text{generalized impedance} \quad (2a)$$

and $[Y_{gen}] = \text{contra}G / \text{cov}G$: generalized admittance (3a)

Table1: Inventory of the Informations carried by a Bond

Covariant factor	On the thick rod.
Contravariant factor	On the thin rod.
Invariant product	On the central axis.
Performance relation	On the front of the bond, between the component rods.
Causality	On the selected end of the bond, with the specific symbols: X, if covariante causality or O, if contravariante causality.
Direction of flows displacements	Each flow moves from the back , locating by the coordinate in the rear bracket to the front, locating by the coordinate in the forward bracket.

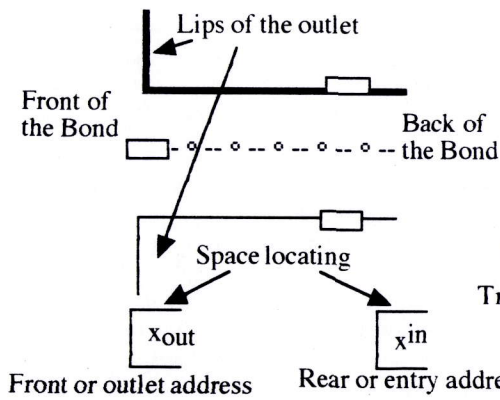

Fig.4: Zonal Partition and Addresses Recording of a Bond

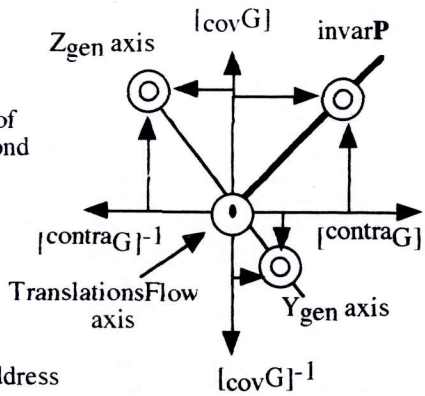

Fig.5: Operational Space of a Bond Multiplicating knot: \odot

Storage relations: Dérivative causality : $[C_{gen}] D_t [covG_p] = [contraG_f]$ (4)

Integral causality: $[C_{gen}]^{-1} \{ D_t^{-1} [contraG_f] \} = [covG_p]$ (5)

with $[C_{gen}] = [^{contra}G_{fl}] / D_t[{}_{cov}G_p]$ generalized capacity of storage

(4a)

Table 2: Comparison between the specificities of Single rod (B.G.) and Both rods (B.G.)”2

Single rod (B.G.)	Both rods (B.G.)”2
Juxtaposition of the ${}_{cov}G$, $^{contra}G$ and their Product on the single rod; what is too compact for keeping a satisfactory synoptical ability	Discriminatory distribution of the ${}_{cov}G$ and the $^{contra}G$, because each one is related to a well reserved rod. Their invariant Product $he {}_{cov}G$, $^{contra}G$ and their Product is localized on the central axis.
Not well appropriate for this performance	Obvious synoptical possibility showing the performance relation between each associated factor.
Not well appropriate for this performance	Easiness for specifying the behaviour of the storage elements. Well suited for distinguishing the Derivative from the Integral working.
Not well appropriate for this performance	Well convenient structure to let appear the duality between the covariante and contravariante components due to the pair of rods.
Asymmetrical disposition for recording the pair of causalities, because of the transversal stroke is used for the covariante on the selected end of the bond. The contravariante one is locating on the opposite end by deducing.	Well adapted symmetrical disposition for recording the pair of causalities, because of the use of the symbol X for locating covariante factor and the O for contravariante one.
Sparsed Memory allocation for recording, what provides economical storage and carriage	Larger range of Memory. More cumbersome for recording.

1.4 (B.G.)² Methodology for Symbolic Description of any Dynamical System

Composition of Complex systems: In any working system, we can detect:

- Input gate for fitting the inflows
- Converter center what is the essential unity for the assigned function
- Dissipative elements
- Storage elements
- Output gate for fitting the outflows

With (B.G.)² methodology it is easy to design for each part of systems a modular network of bonds in correspondence to their basic devices because the tasks of any system are analogous, everywhere. (Fig. 6)

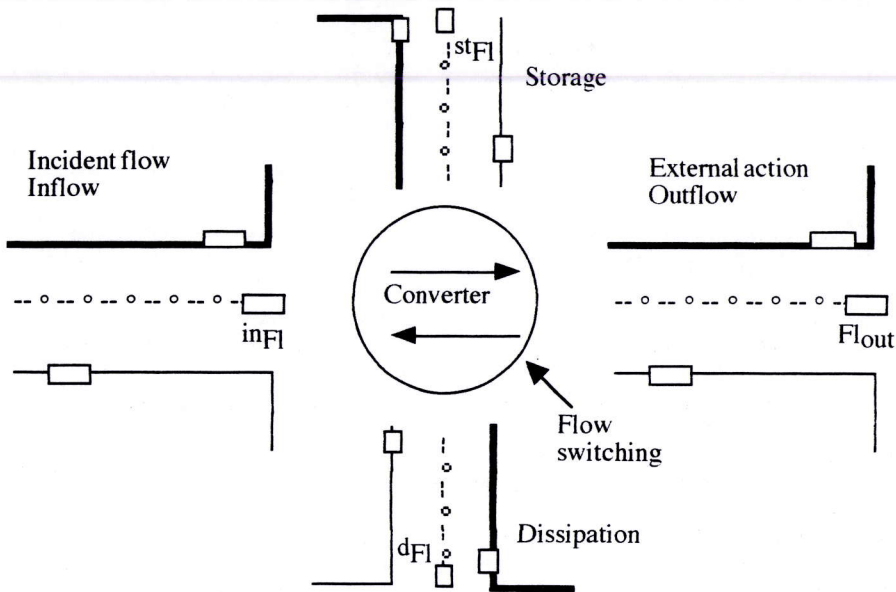

Fig. 6: Synthetic Configuration of any Dynamical System with (B.G.)²

2 Similarities between (B.G.)² and Tensor Topology

2.1 Dual Features of Tensor Structures

Tensor methodology is suitable for a systematic mathematical analysis of every physical phenomenon by means of numbers arrays called Tensors or sometimes Vectors; these last ones with a single line are Tensors of the first order. These numbers are the weighting factors of the causal parameters λ_k which regulate the evolution of $\mathbf{A}[(\lambda_k := a^k]$, physical variable, where a^k are customarily the contravariant weighting of λ_k , denoted by upper index. Consequently the Tensor spaces are embedded with referential axes, geometrical pictures of each λ_k parameter, graduated by the covariant unit tensors \mathbf{e}_k , denoted by lower index, and allowing the evaluation of their contravariant components

a^k . This is a convenient way for displaying the influences of each parameter λ_k on A .

Increasing of the tensor order: by using the Outer or Dilatation Product it is possible to obtain multicovariant unit tensors: $e_{l,k} = e_l \circ e_k$ (6)

and on a dual level, multicovariant components: $a^{l,k} = a^l \circ a^k$ (7)

With this procedure we generate space with $A(N^2)$ axes (= Arrangement of every couple on N elements), if N is the total number of the primary parameters. This 2° order tensor space is elaborated for detecting the influences of any couple of primary parameters on A

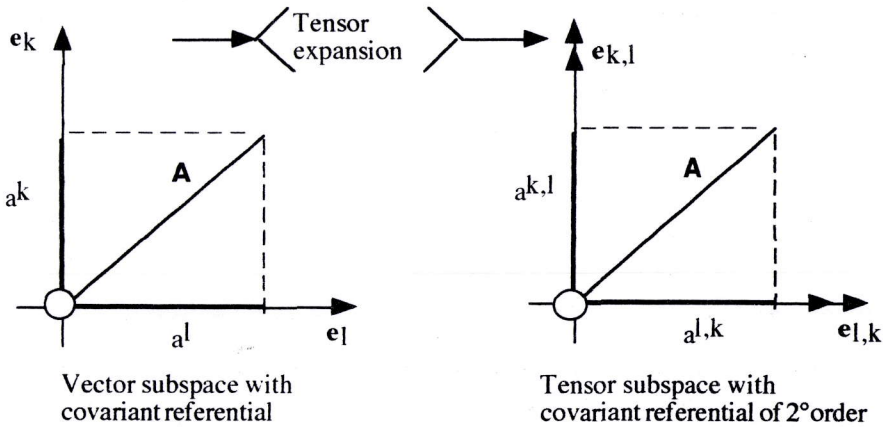

Fig. 7: Synoptical Presentation of a Tensor Expansion from a Vector Space

By going ahead with these Outer Products, we can generate tensor spaces of any p order, where the actions of association of p parameters are detected, where Tensors are equipped with p indices.

Inner or Contraction Products, along pairs of identical indices: one upper and the other lower, allows to let decrease the tensor order of a grade by conjugated pair; and eventually to reach the scalar or invariant stage, if the product contains every pair of upper identical to lower indices. See the (Figs 7, 8).

Example of double inner product leading from a 2° tensor order to the scalar stage:

$$\sum_{k,l} a^{l,k} e_{k,l} = A \quad (\text{scalar drop}) \quad (8)$$

2.2 Use of the (B.G.)² for explaining the Elaboration of the Tensor Spaces

Because the duality is also a fundamental property of the (B.G.)² they seem well suitable for codifying the tensor quantities on a flow topology (Figs. 8, 9)

The (Fig.8) introduces the Vector Bond, equipped with a cross stroke for reminding of the indicial sweeping k over each axis.

On the (Fig.9), we discover the Tensor Bond of 2°order composed of a double covariant rod to notice the grouping of the basic vectors: $e_l \circ e_k = e_{l,k}$, and on the other side of

double contravariant rod to notice the grouping of the components: $a^l \circ a^k = a^{l,k}$

On the Tensor Bond of 2°order it is necessary to dispose of 2 cross strokes for the double

indicial sweeping because we have to associate each basic vector \mathbf{e}_l and each component a^l respectively with \mathbf{e}_k and a^k . (Fig.10)

Consequently we may conclude that the Bonds are synoptical tools to underline the characteristics of Tensors.

2.3 Convolution and Tensors

Any tensor product is to be considered like convolution product of a parameter λ_l along the other λ_k .

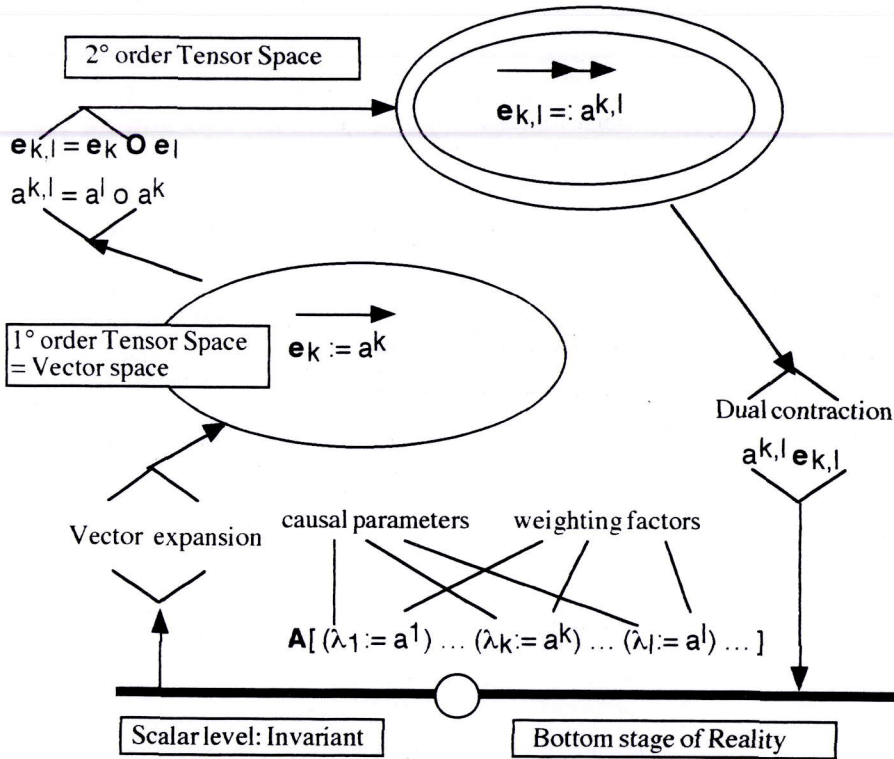

Fig.8: Functional Picture of Outer (Dilatation) and Inner (Contraction) Products for building Tensor Spaces

3 Operational Description of the Modulation

3.1 Structure of any Modulation

The modulation of a signal is composed of a carrier and of the modulating signal to involve a modulated outflow.

The carrier must be a monotonous selected operator without any specific information to give the signal a transformed shape better suitable for the further operations, what is

similar to a transfer into a new topology. The carrier provided by the modulating system will be considered as a covariant agent .

The modulating signal supplies the informations flow, what is a quantitative agent and therefore it may be considered as the contravariant element.

This functional analysis allows to discover the duality of modulations and the structural analogy with the tensor topologies.

We note that modulation procedure is equivalent to a convolution product of the modulating signal with the carrier and consequently is also analogous to tensor product.

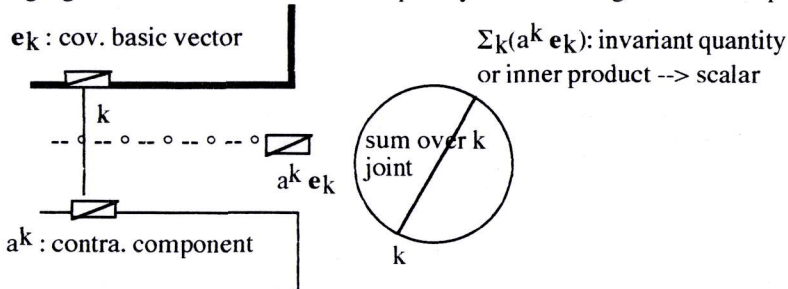

Fig 9: Structuring Bond for a Vector Space

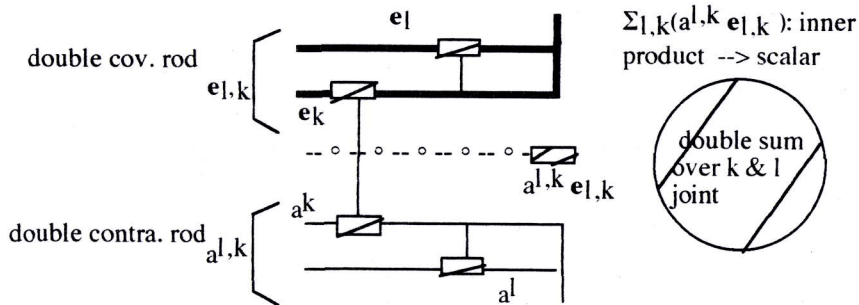

Fig.10: Structuring Bond of a 2° order Tensor Space

3.2 Analogy between Bonds and Modulations

Because Duality is also the main property of the Bonds, they are the best fitted tools for transposing modulations in a topological frame (Fig. 11).

4 Dual Description of Information Flows

4.1 Structure of Knowledges Flows

Any elementary knowledge, called topic quantum, is to be identified according its kind or domain and afterward evaluated in relation to its informations quantity.

We immediately deduce that a knowledge flow has a dual structure and is also able to be analyzed by means of (B.G.)² methodology (Fig. 12).

4.2 Knowledges Recording and Modulation

For an easy manipulation, each topic quantum is to be distributed in the appropriate sector of the data bank, in order to be quickly and accurately located for further operations. The Sorting is performed by a set of well suited selectors which form the operational frame of any efficient info.processing. Therefore the choice of a well adjusted selectors vector is crucial for building an efficient sorting system. We may deduce that there is a tight correlation with Modulation, if we compare the selectors vector to a carriers vector and the information quantity to the modulating signal. (Fig. 12).

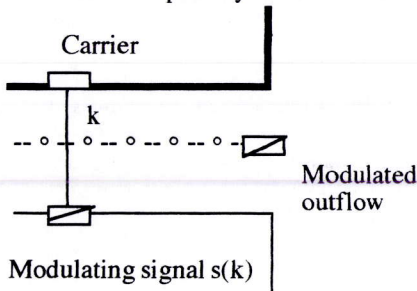

Fig.11: Bond for Modulation

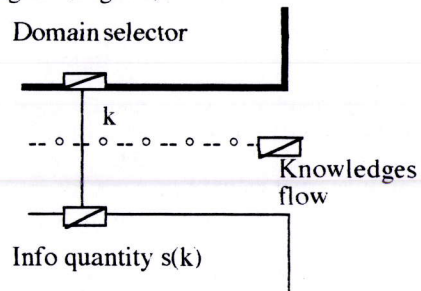

Fig.12: Bond for Knowledges Flow Processing

4.3 Comparison of a Technological System with a Topics Sorting, under the Flow View

Table 3: Substitutions for transferring Bonds Net from Technology to the Knowledges Processing

Technology	Knowledges Processing
Ingate Converting Centre	Sensors Kind Detector & Sorting Unit for switch Info.to specific Memory Sectors
Storage	Additional Knowledges distributed in Memories
Dissipating	Leackages or Forgetfulness
Outgate	Further Act or Consequent Behaviour

Knowledges Capture and Sorting constitute a dynamical soft system where info.flows are dealt and consequently it has to work alike any other active system. Therefore the Bond Net of (Fig.6) is also convenient for the knowledges processings; if we bring in each part the adequate substitutions, as indicated in the table (3).

5 Duality, Informations and Knowledges in this communication

5.1 Informations

It is obvious that any recoded sign or event carries intrinsically some information

which may eventually concern our investigative fields.

5.2 Knowledges

Knowledges are recorded, ranked sorted and classified informations. They are modulated informations and are stored in data banks. Consequently of their added value due to their dual partition, they can be sold bought and tranfered. They elaborate the strategical topics for developping our skills and for improving our future behaviours. See (Fig.13 & 16).

5.3 Duality

Duality or dual analysis is the decomposition of the internal structure of any topic or idea into their qualitative and quantitative components. This dual partition is the basic operational key for recognizing the field of application of the knowledges (quality or covariance) and estimating their level or intensity (quantity or contravariance). This dual approach helps for understanding the internal structure of things and events. See (Fig.13).

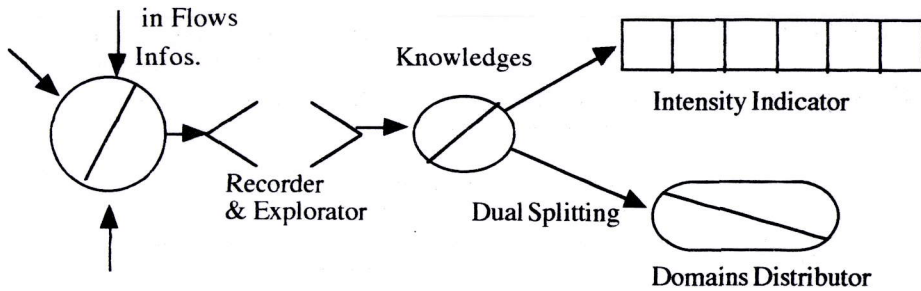

Fig. 13 : Transformation of Informations into Knowledges and their Dual Analysis

6 Dynamical Features of the (B.G.)”2

It is of high interest to let observe that the bonds may be considered as multicarriage devices. Indeed they simultaneously indicate different types of mobilities for various variables as described in the following list. See (Fig. 15 & 16).

Migration of the resultant invariant Product Flow from the inlet address to the outlet one.
Winding of the Contravariant set around the covariant fixed potential frame.

Choice of a particular causality what determines an argument factor; this last one will go across the performance relation according the orientation of the arrows to gift at the outdoor of the operator the elaborated conjugated variable.

Implicit drops from the central flow axis to each of the rods ; what corresponds to geometrical projections.

These observations and interpretations allow to highlight the many various kinetical abilities of each bond.

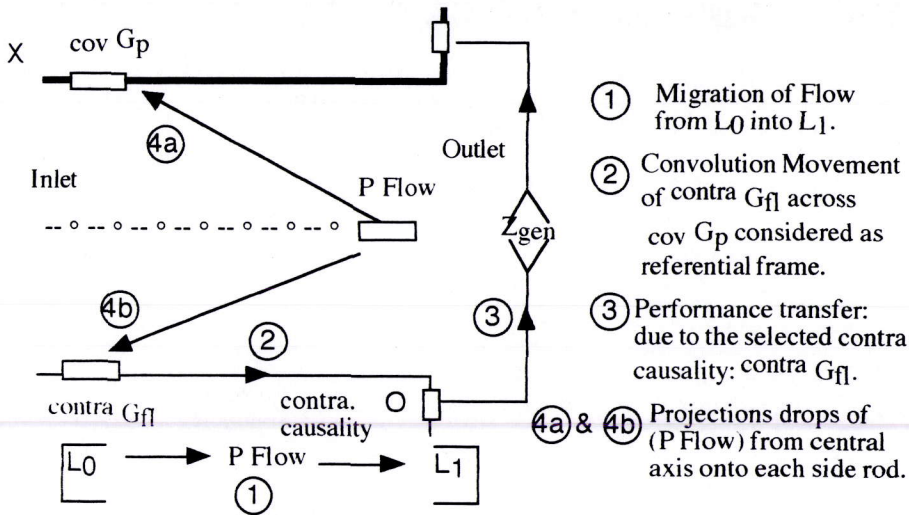

Fig.14: Inventory of every kinetical Behaviour of a Bond

7 Proof of this Methodology

This communication is essentially supplied:

- by observing the dual kind of every sign in our world that carry the covariante (qualitative) and contravariante (quantitative) features
- by deducing the functional analogy between the tensor configuration, the modulations and the distributions or ranking of the knowledges
- by using the (B.G.)² to let synoptically reveal the dual composition of these subjects
- by comparing the language structures (grammar and vocabulary) with the thoughts elaborations (application domain and additional beared knowledge)
- The set of the Figs.(7.8.9.10.11.12.13.15.16) and the tables (3.4) justify without any doubt, by means of their dual shape and content, the well founded deductions and the rigour of our reasoning. These figures are the main items for showing the power and conviviality of this topologic methodology.

6. Conclusion

6.1. List of a few operational advantages deduced from this research

Extended additional use of "Bond- Graphs", which appear like synoptical browsers, for logically explaining the structural duality by catching and storing the informations.

Underlining of the mutual interaction between the referential and the specific meaning of any memorized information.

Display of the functional analogy between modulation and topic selection.

Addition of a similar operational bridge between the systems drivers from the technology and these ones from the "soft" domain. (Fig. 15 & 16).

6.2. Duality supplies Anticipative Items

Development of a uniform synoptical procedure by exploring a set of various domains for easily detecting and retrieving informations with help of selected right referentials; what is a duality consequence. See table (4).

Hopefully this synoptical procedure will save time and efforts for the analysis of any system, what is to be the main advantage of anticipative procedures.

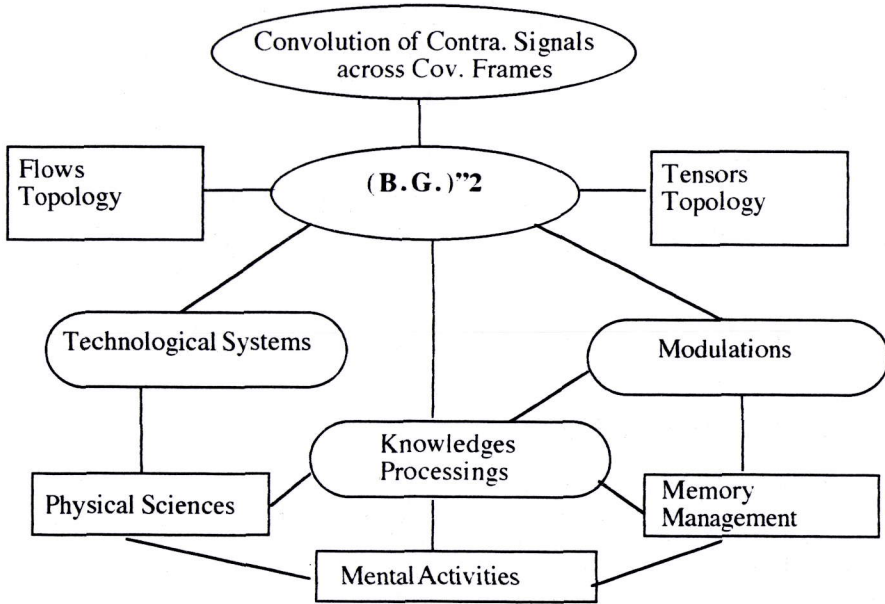

Fig.15: Functional Correlations between a few Domains built upon Duality

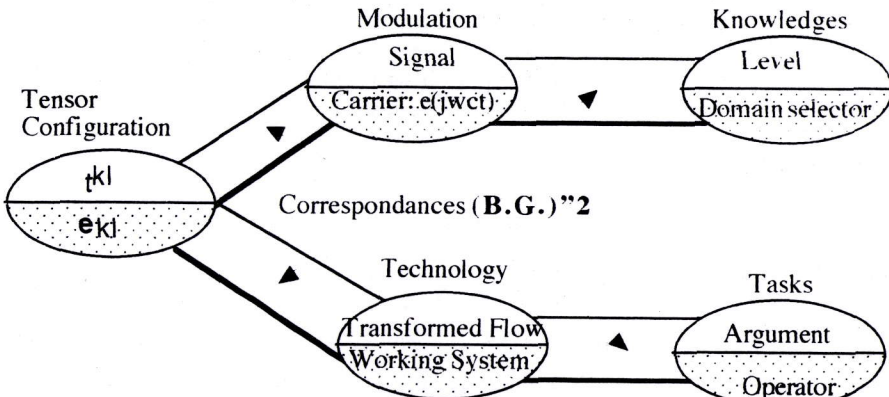

Fig.16: Synthetic Presentation of Dual Composition in a few Domains

Table 4: Covariante & Contravariante Features in a few Topics

Domains	Covariante Nature	Contravariante Nature
General Concepts in any Science	Referential Potentials Levels Qualities Influences Parameters	Variables Flows Fluences Quantities Rates of Influences
Vectors & Tensors Fields	Cov. Basic vectors Cov. Tensors Unities	Contra. Componants
Networks	Networks Structures	Load flows
Modulations	Carriers	Modulating Signals
Knowledges Processings	Domains Selectors	Info. Quanta
Systemic	Subsystem Architecture	Flows Transformations
Computing Science	Algorithmic Structures	Data Flows
Transports	Vehicles Ships	Freight Shipments

References

- Landau & Lifchitz. (1968) *Théorie des Champs*. Ed. Mir (Moscou)
- Cantraine G. (1970) *Electronique Générale*. Université de Liège
- Doucet J.A. (1998) Topographical Mapping of Convolutions by means of the "Bond-Graphs". 15^o International Congress on Cybernetics (Namur, Belgique)
- Hay G.E. (1953) *Vector & Tensor Analysis*. Dover Publications.(New York)
- Karnopp D. & Margolis D. & Rosenberg.(1990) *System Dynamic*. Ed. John Wiley (New York)